



Standard Inventory Item

6.5 PRC M2

7B0B33

Manson Reamers

Contact us at:
support@mansonreamers.com
(810) 953-0732

8200 Embury Rd
Suite 1
Grand Blanc, MI 48439

6.5 PRC M2

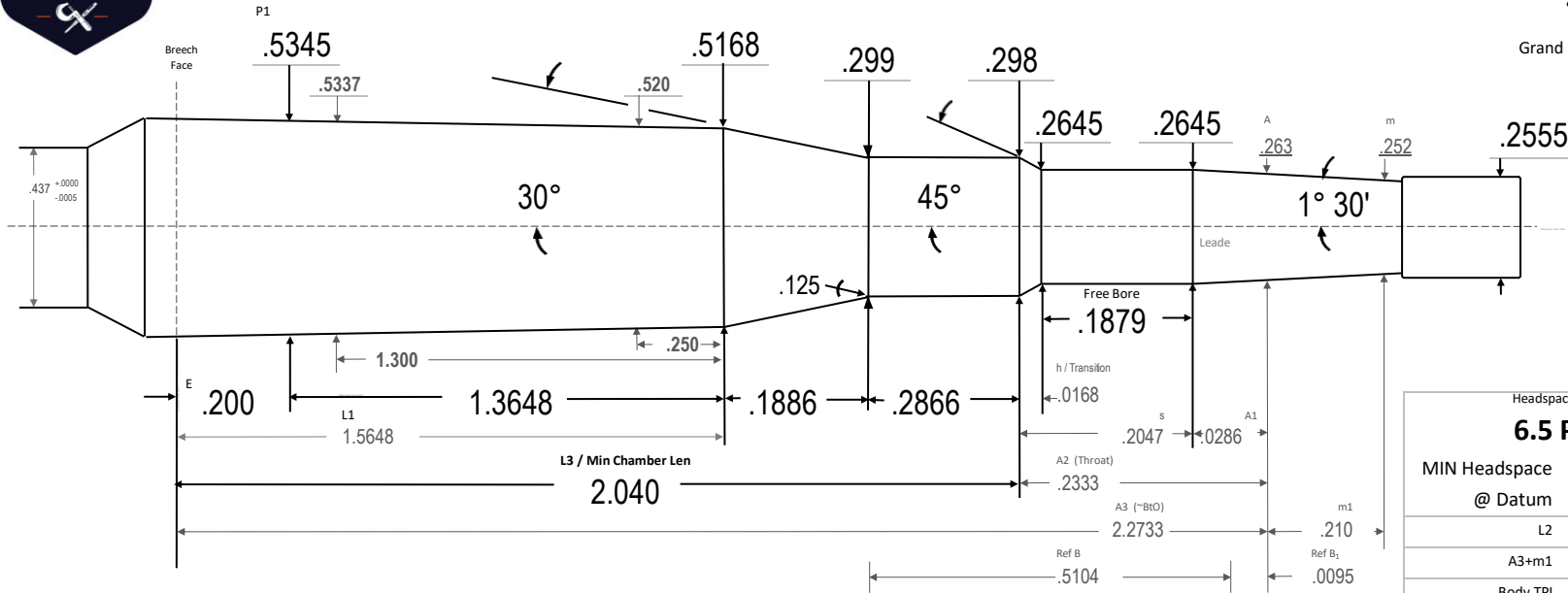

Manson 2 version. Chamber is minimum SAAMI spec with the exception of the larger P1 diameter, to address reported extraction issues

Headspace Gage:	
6.5 PRC	
MIN Headspace	1.6486
@ Datum	.4200
L2	1.7533 89
A3+m1	2.4833 37
Body TPI	.0129 69
Breech Face Dia	.5370 94
~Chamber Vol in ³	.3665 24
Drawn:	Ray Gross
SD	2024.01.18
Template PTL	V10.2 24.01.10
Dia Tolerance	+ .001/- .000
Length Tolerance	+ .005/- .000
Angle Tolerance	+/- 15'
Use Reamer Blank	6.5 PRC
Print is not to scale	



6.5 PRC M2

6.5 PRC M2